

# HALE HOLDER

■ HBA ■

# MICRO HEAD



Vacuum chamber

Sealing surface

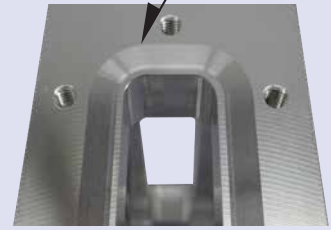

Rubber mold

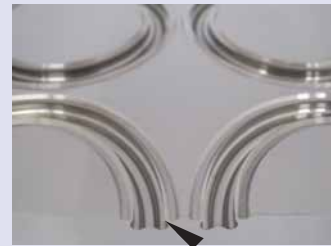

Mirror finish



# System

## Head

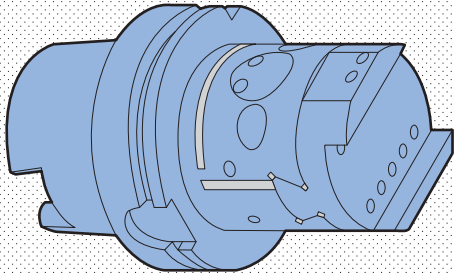

Type 70

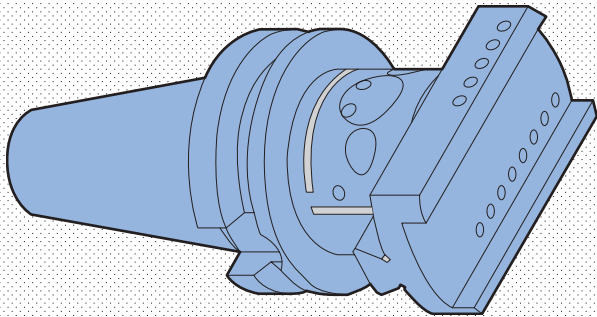

Type 120

## Head

### Type 70

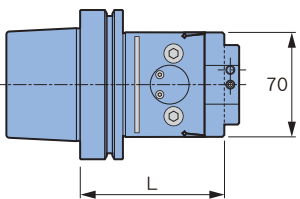

CODE	L
<b>BT40</b> - HBA70 - 106	106
<b>BT50</b> - HBA70 - 106	106
<b>A63</b> - HBA70 - 108	108
<b>A100</b> - HBA70 - 97	97
<b>F63S01</b> - HBA70 - 106	106
<b>F63S02</b> - HBA70 - 108	108

### Type 120

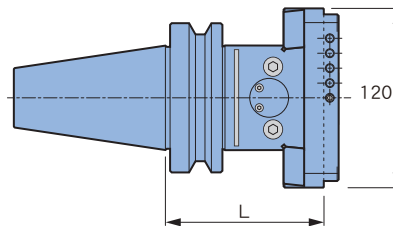

CODE	L
<b>BT40</b> - HBA120 - 106	106
<b>BT50</b> - HBA120 - 106	106
<b>A63</b> - HBA120 - 108	108
<b>A100</b> - HBA120 - 97	97
<b>F63S01</b> - HBA120 - 106	106
<b>F63S02</b> - HBA120 - 108	108

## Cartridge

## Cutter

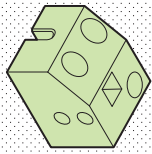

Square shank

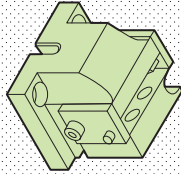
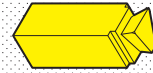

Flat bar shank

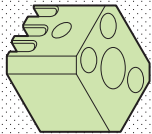
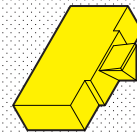

Round shank/  
1 hole

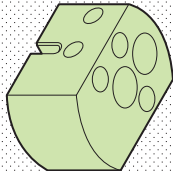
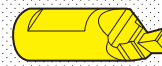

Round shank/  
2 holes

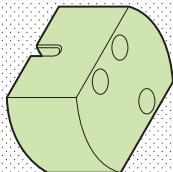
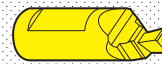

Blank

## Cartridge

### Square shank 6, 8, 10, 12mm

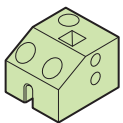

Square shank  
Cartridge

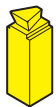

Square shank

CODE	Adjustable range (offset amount)	
	HBA70	HBA120
<b>HB-S 6</b>	0~22.5	0~52.5
-S 8		
-S10		
-S12		

### Flat bar shank Thickness 6, 7, 8mm

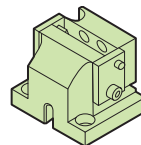

Flat bar shank  
Cartridge



Flat bar shank

CODE	Adjustable range (offset amount)	
	HBA70	HBA120
<b>HB-F8.5</b>	0~22.5	0~52.5

### Round shank/1 hole $\phi 16, 18, 22$

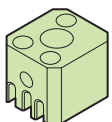

Round shank  
Cartridge 1 hole

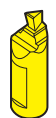

Round shank

CODE	Adjustable range (offset amount)	
	HBA70	HBA120
<b>HB-R16-1</b>	-10~32.5	-10~62.5
-R18-1		
-R22-1		

### Round shank/2 holes $\phi 16, 18, 22$

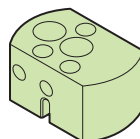

Round shank  
Cartridge 2 holes



Round shank

CODE	Adjustable range (offset amount)	
	HBA70	HBA120
<b>HB-R16-2</b>	0~52.5	0~82.5
-R18-2		
-R22-2		

### Blank

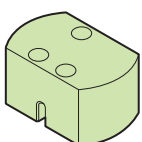

● DIY modification

CODE
<b>HB-BL</b>

# Features

## Precisely set the radial alignment of the cutter edge

Cutter position can be adjusted depending on the cutter configuration or the program

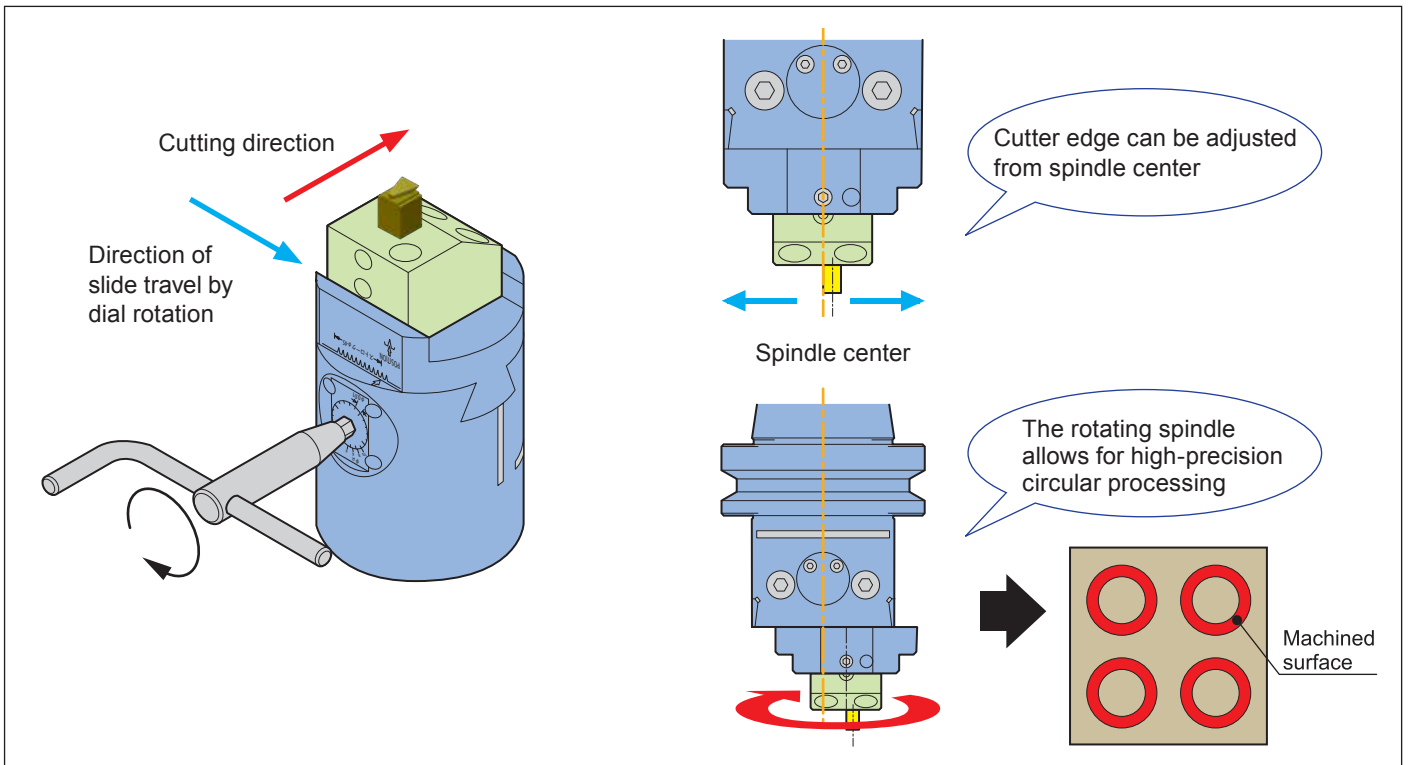

## Superior finishing surface at radial corner

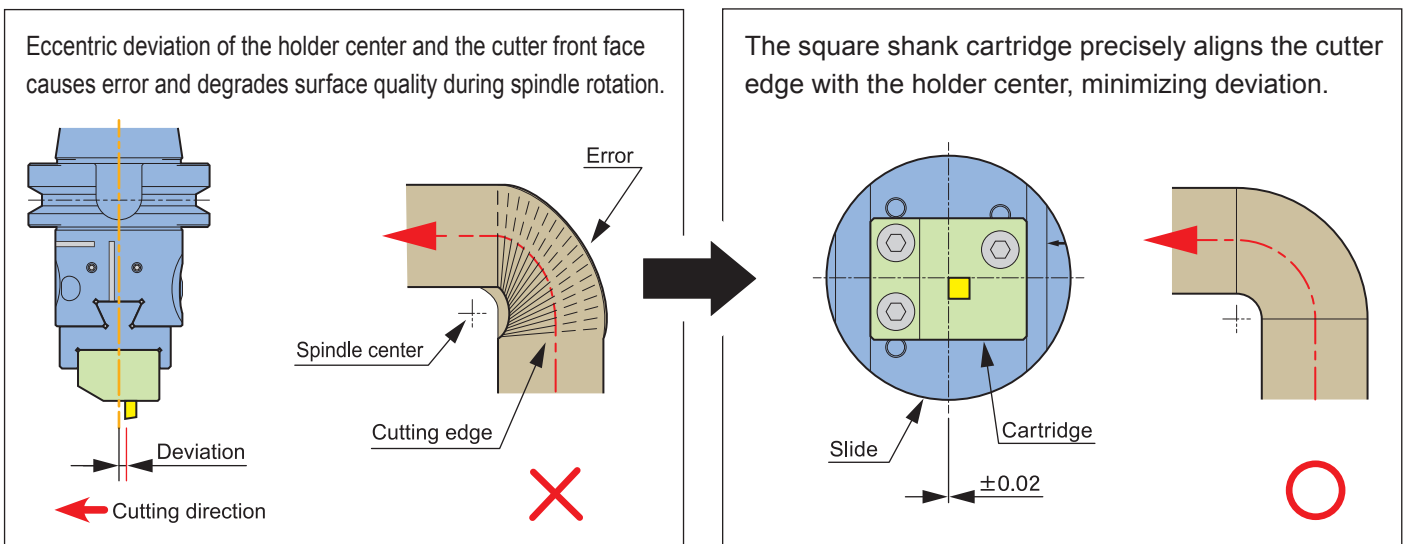





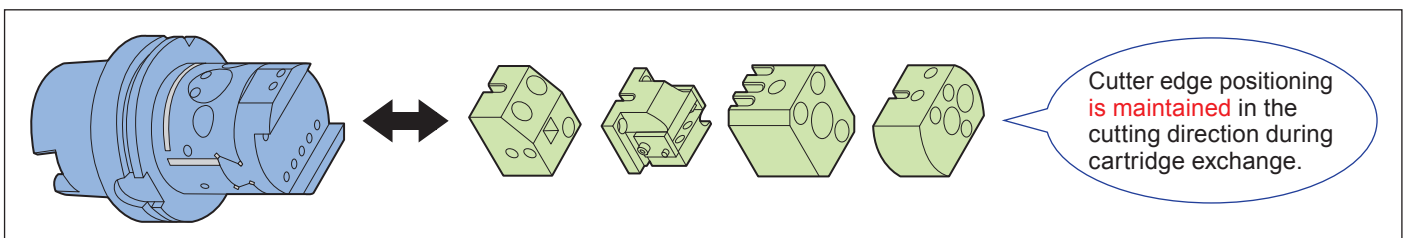

## Cartridge system

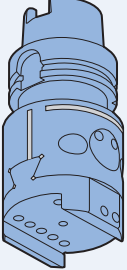
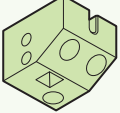
Square, flat bar, round shank (side-lock) are available.

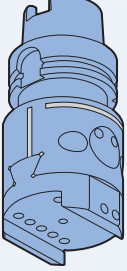
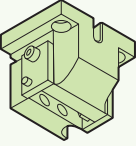

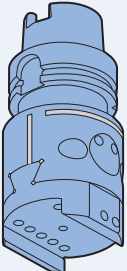
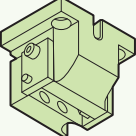
# Cutting data

Material	Tooling			Cutting parameter			Surface roughness Rz(μm)	
	Head	Cartridge	Cutter	Feed (mm/min)	Ap (mm)	Zero cut	Feed direction	Normal direction
A5052	A63-HBA70-108 	HB-S12 	Square shank / A5052 [Cutter] Single-crystal diamond [Brand] TOKYO DIAMOND (JPN) 	1000	0.005	1time	0.42	0.24
SUS304	A63-HBA70-108 	HB-F8.5 	Flat bar shank / SUS304 [Cutter] Ultrafine-grained cemented carbide TiN coating [Brand] TOKO (JPN) 	500	0.0035	2 times	0.44	0.74
NAK80	A63-HBA70-108 	HB-F8.5 	Flat bar shank / NAK80 [Cutter] Ultrafine-grained cemented carbide TiN coating [Brand] TOKO (JPN) 	500	0.005	2 times	0.26	0.55

**End-milling surface**

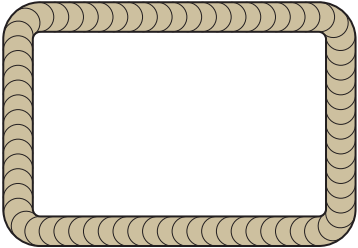

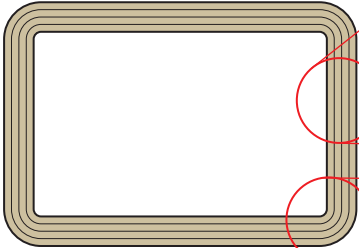

Cutter mark in normal direction

**Hole machining**

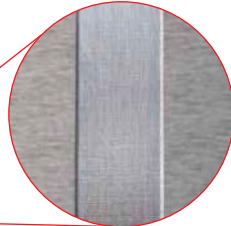
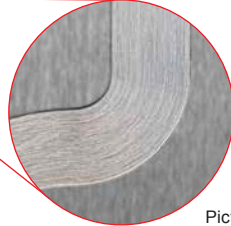

Good sealing surface

Picture:material SUS304

# HBA70 Square shank

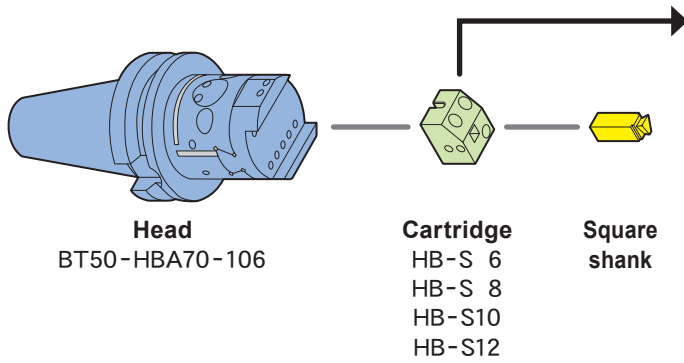

• Cartridge

CODE	A	B	C	D	E	F	G
<b>HB-S 6</b>	6	35	4	10	20	28	134
<b>-S 8</b>	8	35	4.5	10	20	28	134
<b>-S10</b>	10	39	5.5	12	32	32	138
<b>-S12</b>	12	39	5.5	12	32	32	138

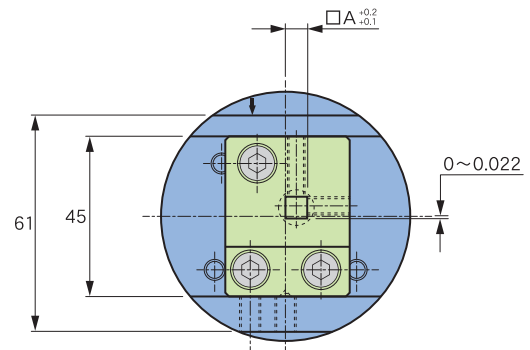

Stroke range from center: 22.5mm

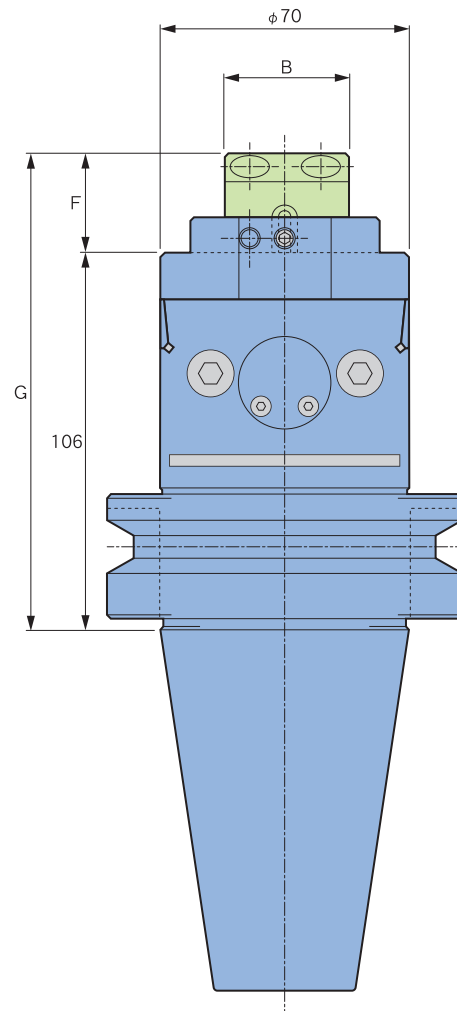
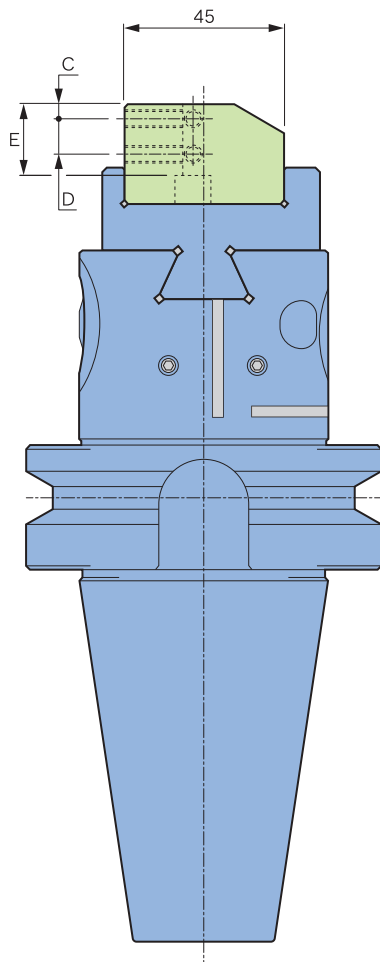

# HBA70 Flat bar shank

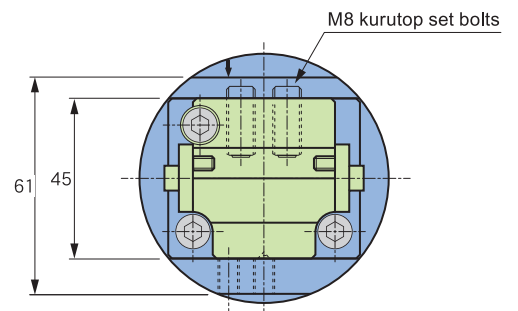
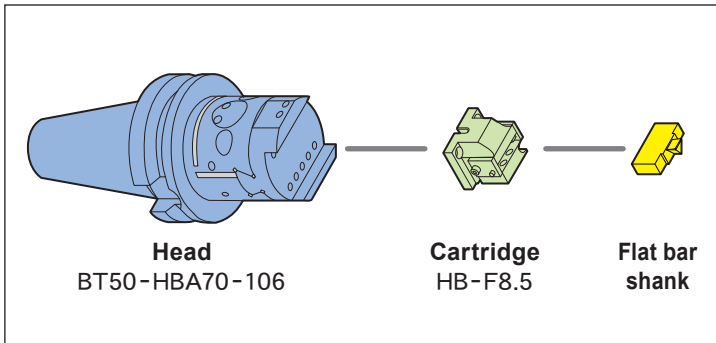

Stroke range from center: 22.5mm

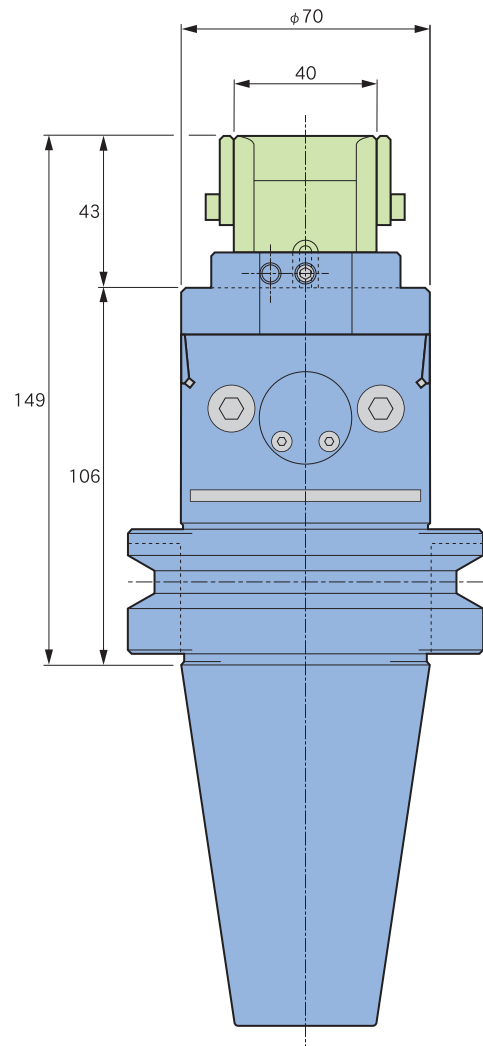
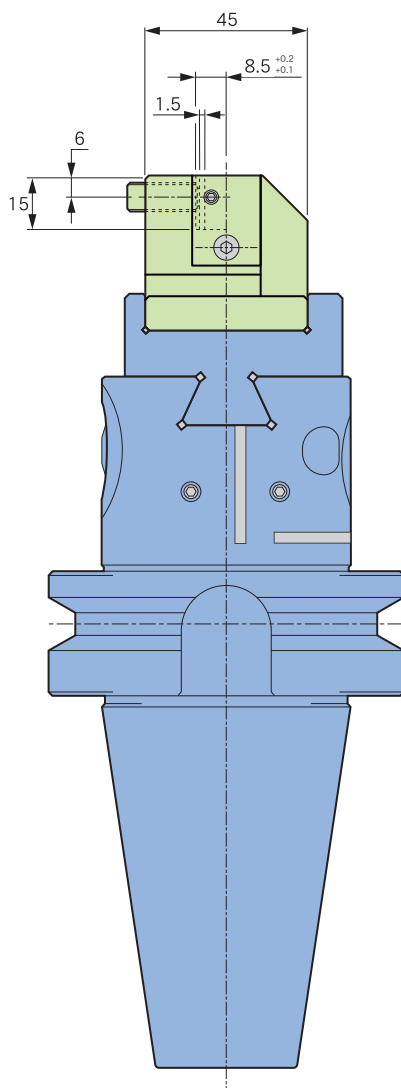
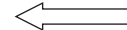

# HBA70 Round shank/1 hole

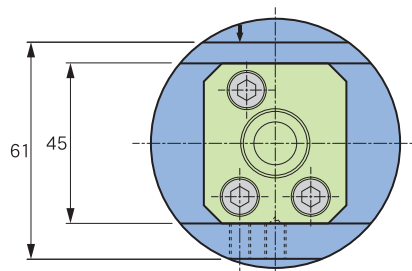
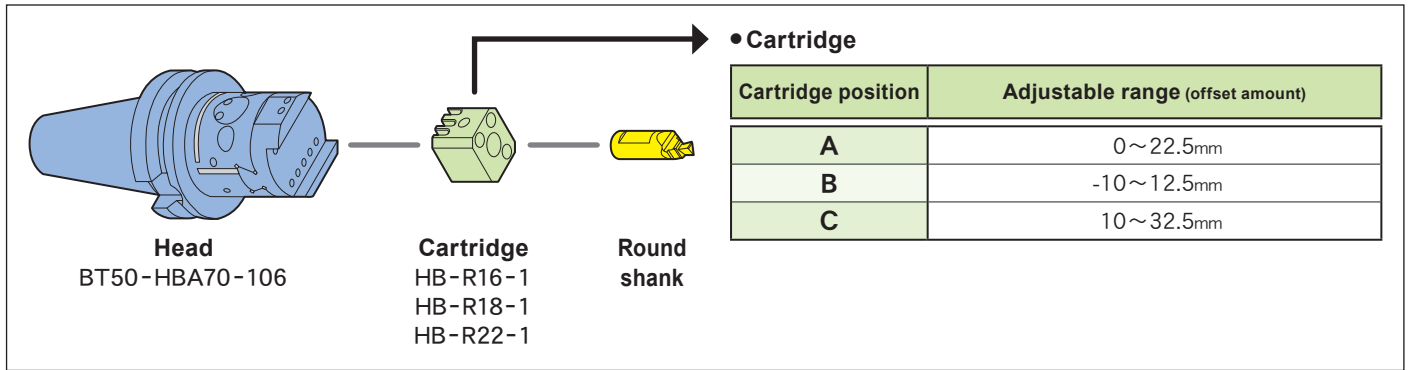

Cartridge position A

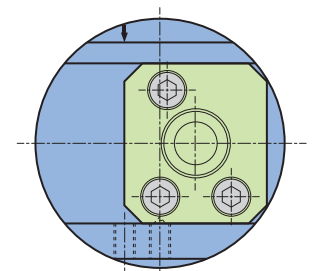

Cartridge position B

Stroke range from center: 22.5mm

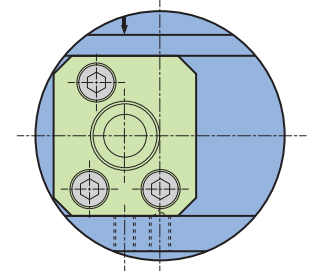
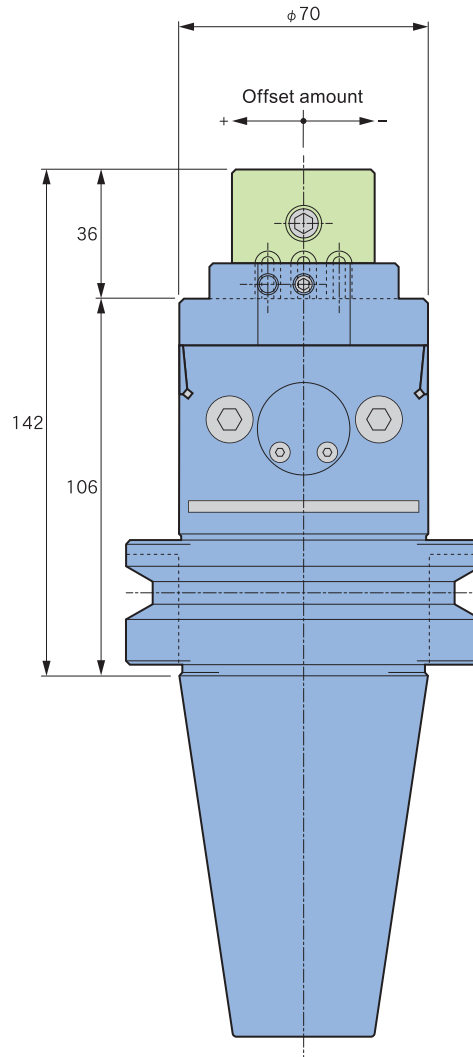
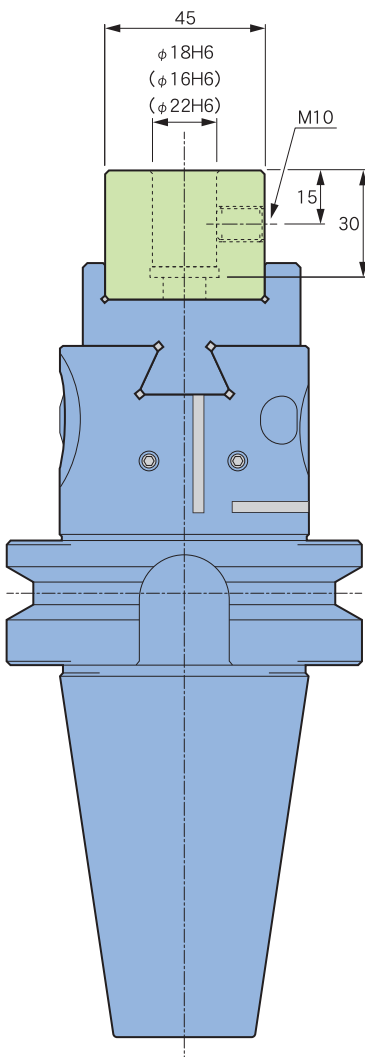
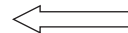

Cartridge position C

# HBA70 Round shank/2 holes

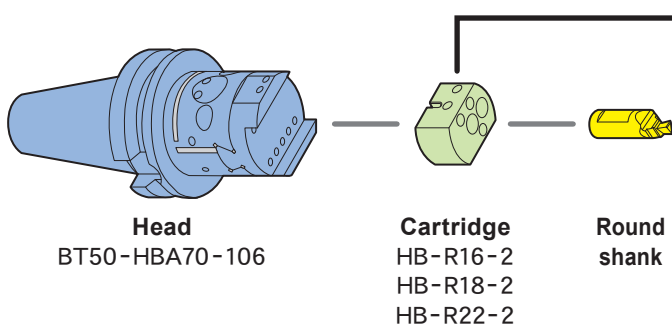

## • Cartridge

Cartridge position	Adjustable range (offset amount)	
	Cutter position A	Cutter position B
A	0~22.5mm	20~42.5mm ※ 1
B	10~32.5mm	30~52.5mm ※ 2

※ 1 ~ 2: For HB-R22-2, offset amount increase +4mm.

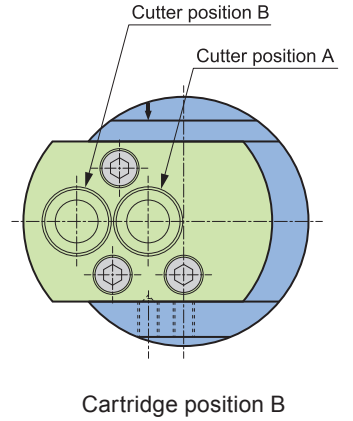
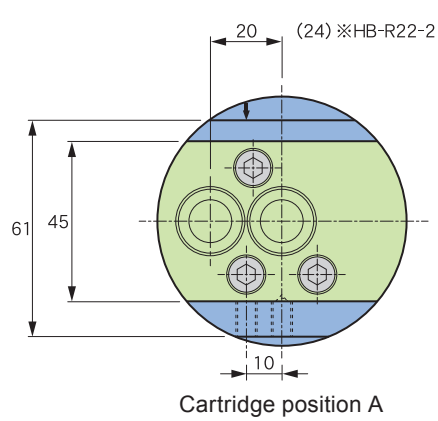

Stroke range from center: 22.5mm

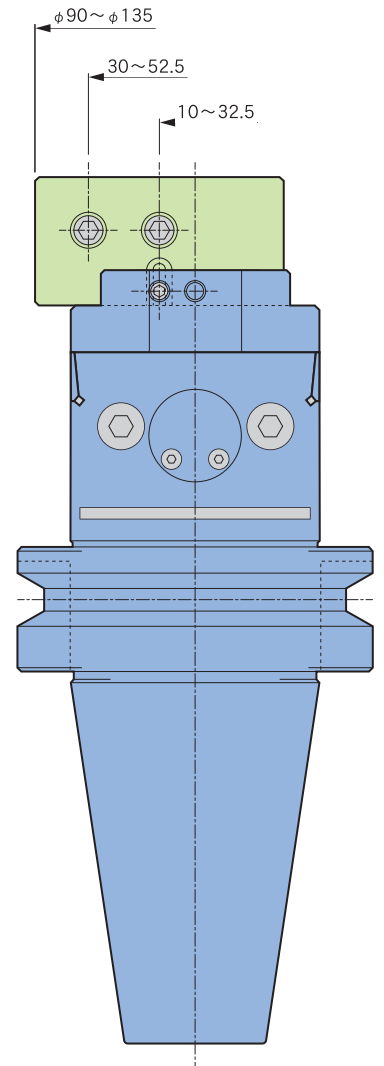
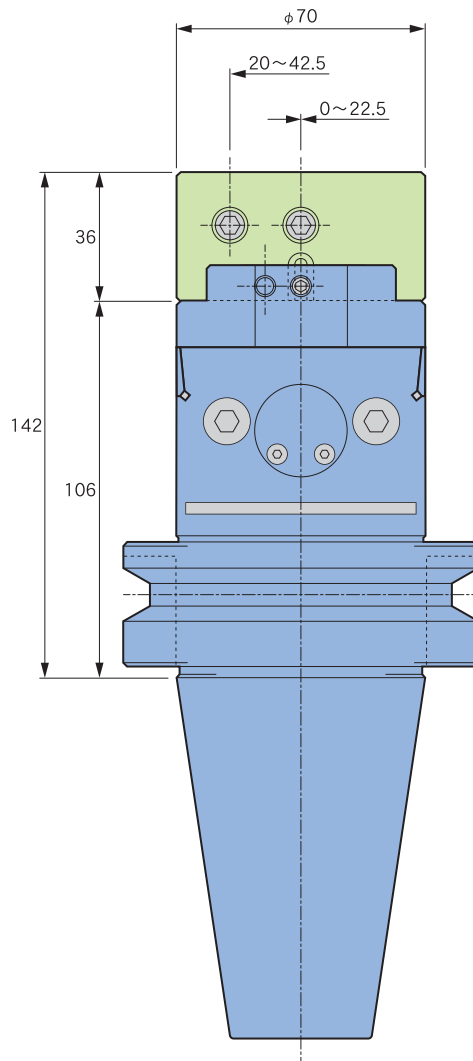
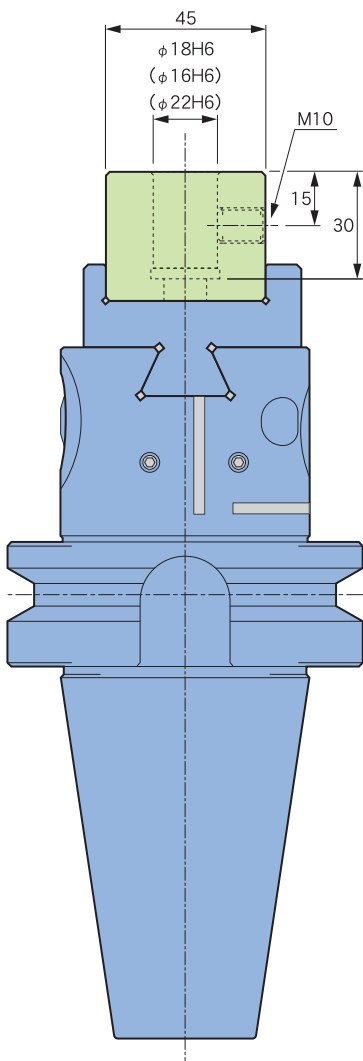
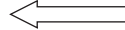

# HBA70 Blank cartridge

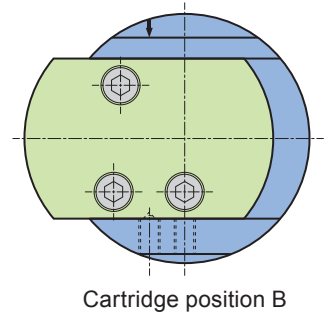
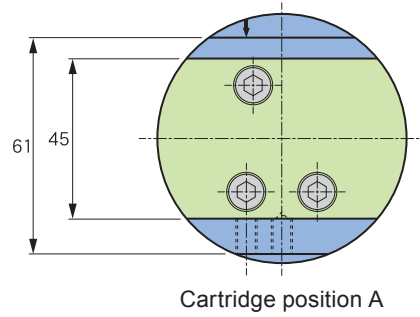
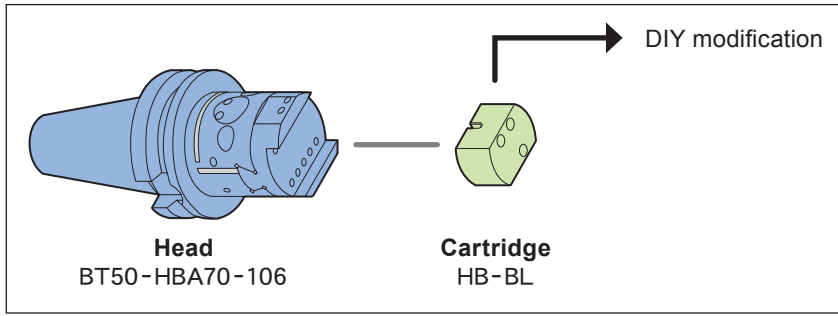

Stroke range from center: 22.5mm

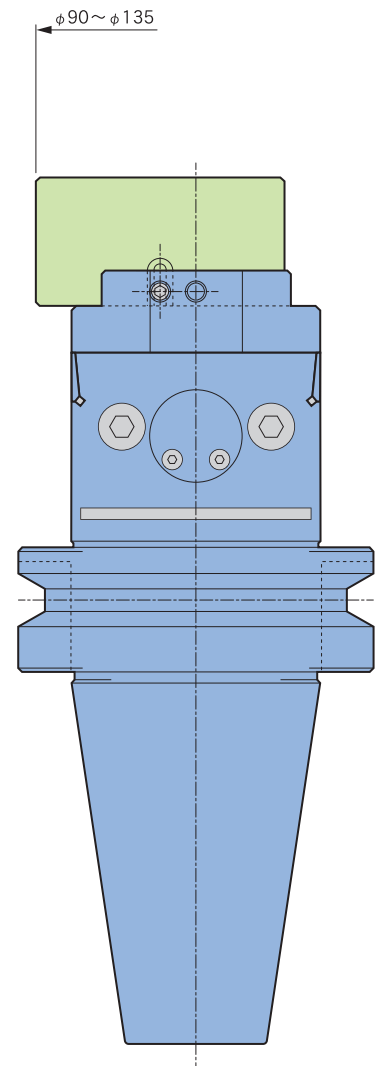
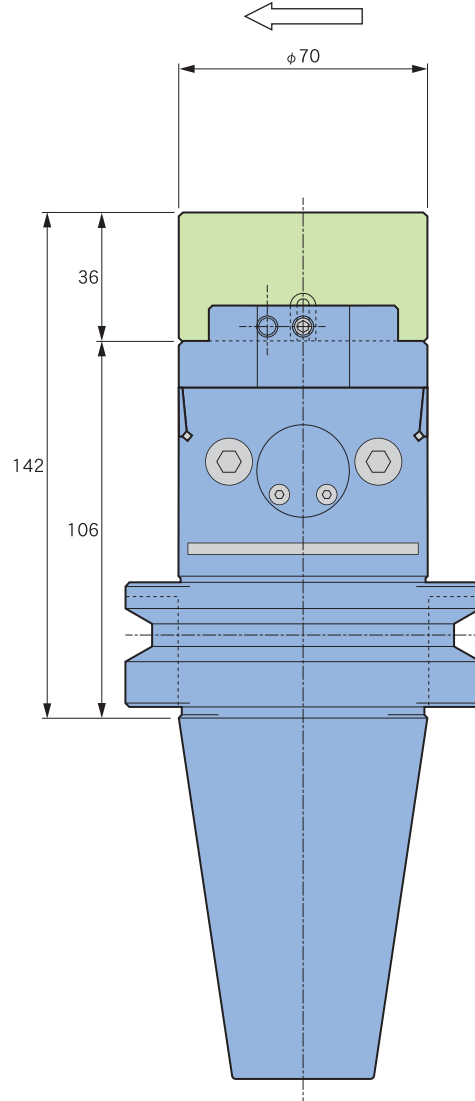
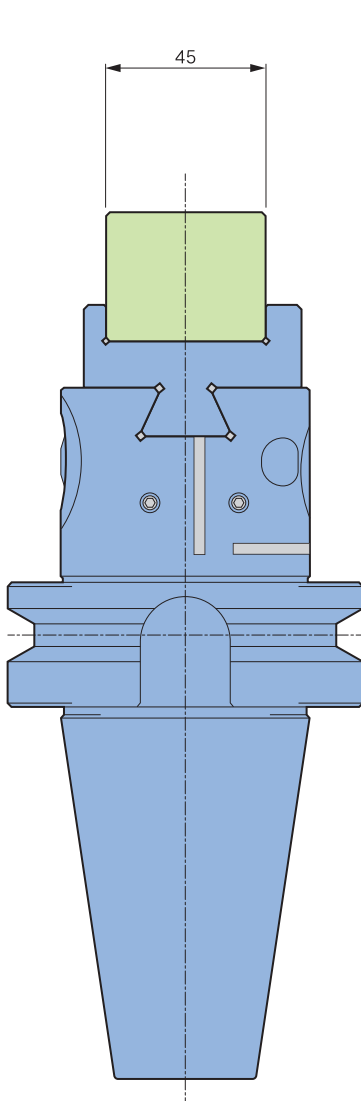

# HBA120 Square shank

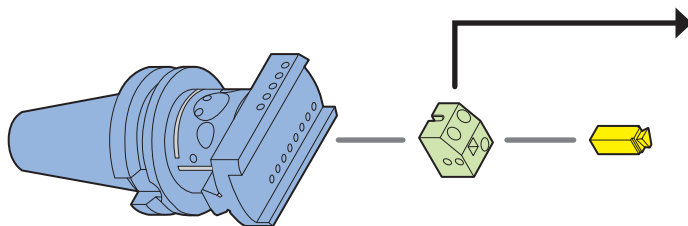

**Head**  
BT50-HBA120-106

**Cartridge**  
HB-S 6  
HB-S 8  
HB-S10  
HB-S12

**Square shank**

• Cartridge

CODE	A	B	C	D	E	F	G
<b>HB-S 6</b>	6	35	4	10	20	28	134
<b>-S 8</b>	8	35	4.5	10	20	28	134
<b>-S10</b>	10	39	5.5	12	32	32	138
<b>-S12</b>	12	39	5.5	12	32	32	138

Cartridge position	Adjustable range (offset amount)
<b>A</b>	0~22.5mm
<b>B</b>	10~32.5mm
<b>C</b>	20~42.5mm
<b>D</b>	30~52.5mm
<b>E</b>	40~62.5mm

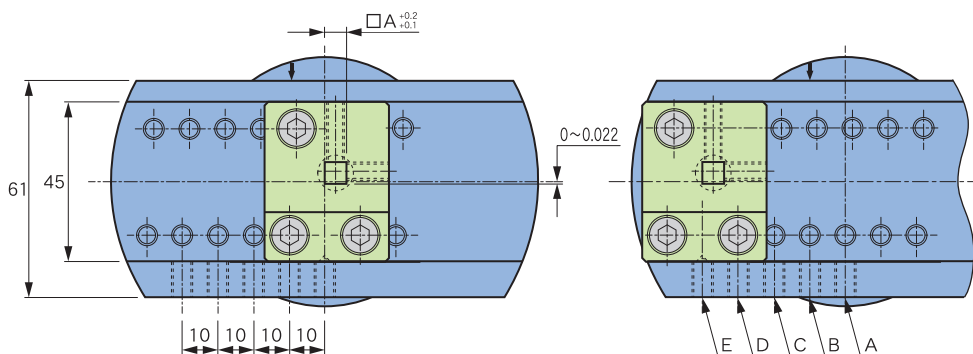

Stroke range from center: 22.5mm

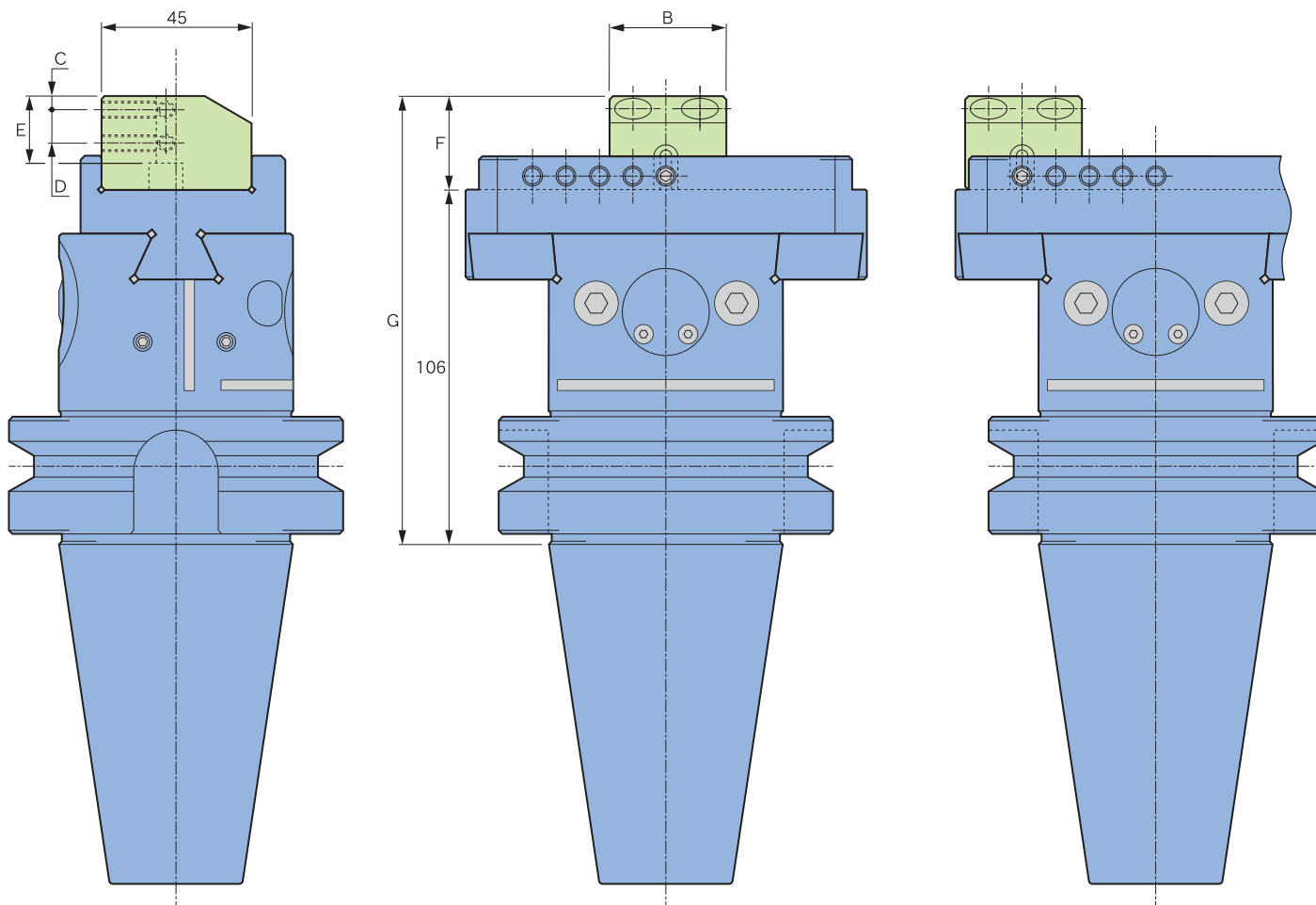
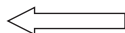

# HBA120 Flat bar shank

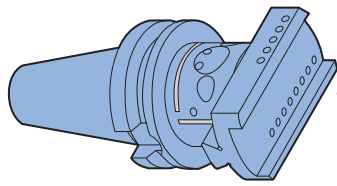

**Head**  
BT50-HBA120-106



**Cartridge**  
HB-F8.5



**Flat bar shank**

• Cartridge

Cartridge position	Adjustable range (offset amount)
A	0 ~ 22.5mm
B	10 ~ 32.5mm
C	20 ~ 42.5mm
D	30 ~ 52.5mm

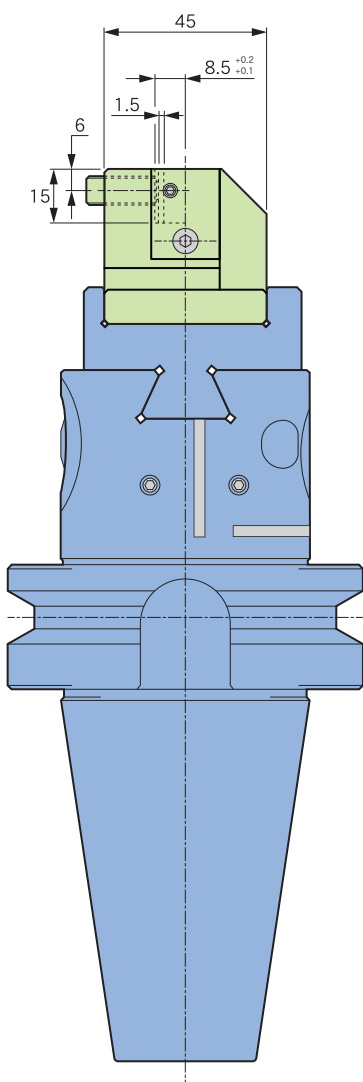
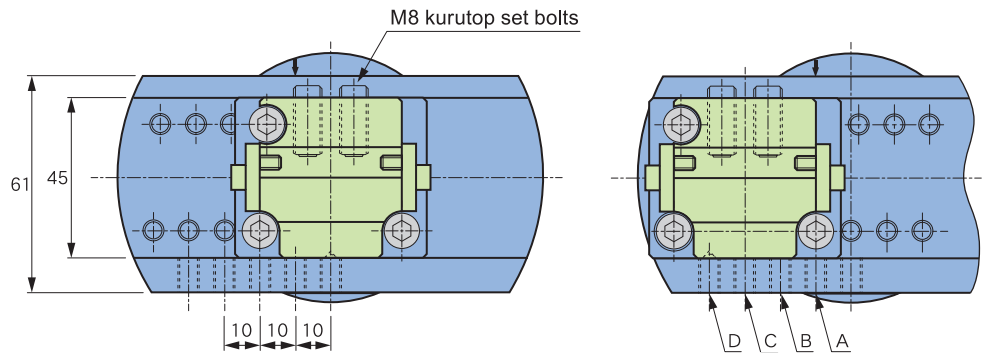

Stroke range from center: 22.5mm

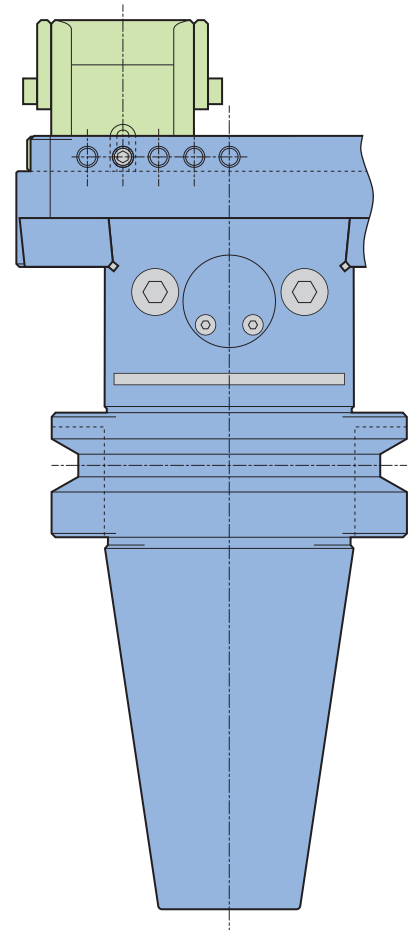
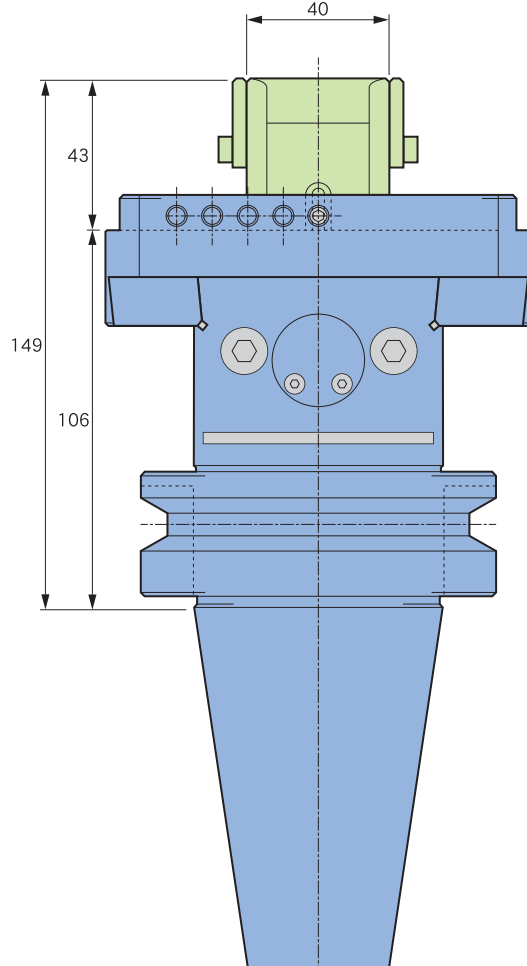
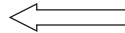

# HBA120 Round shank/1 hole

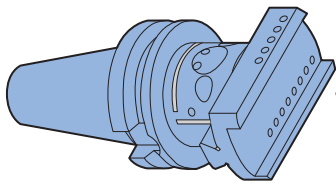

**Head**  
BT50-HBA120-106



**Cartridge**  
HB-R16-1  
HB-R18-1  
HB-R22-1



**Round shank**

• Cartridge

Cartridge position	Adjustable range (offset amount)
A	-10~12.5mm
B	0~22.5mm
C	10~32.5mm
D	20~42.5mm
E	30~52.5mm
F	40~62.5mm

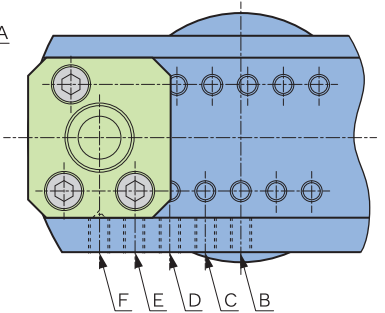
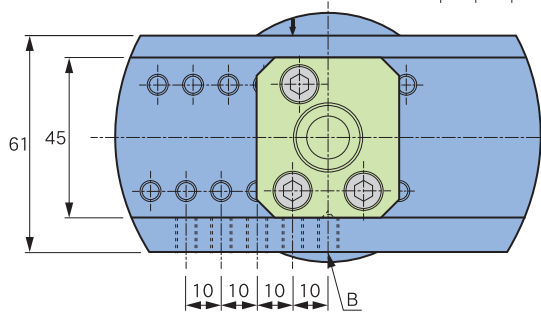
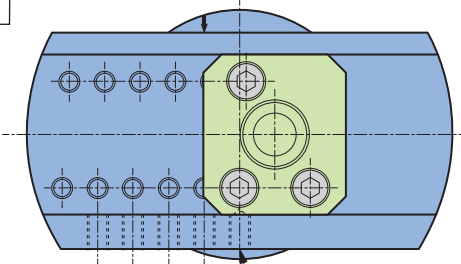

Stroke range from center: 22.5mm

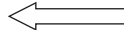

40  
0~22.5

40~62.5

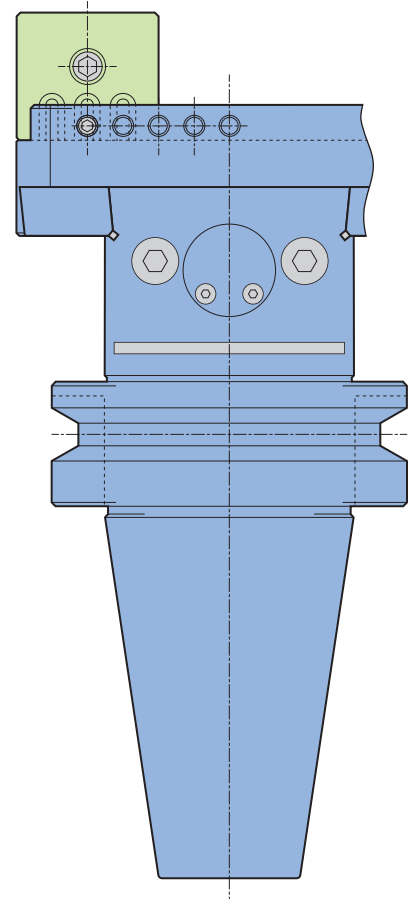
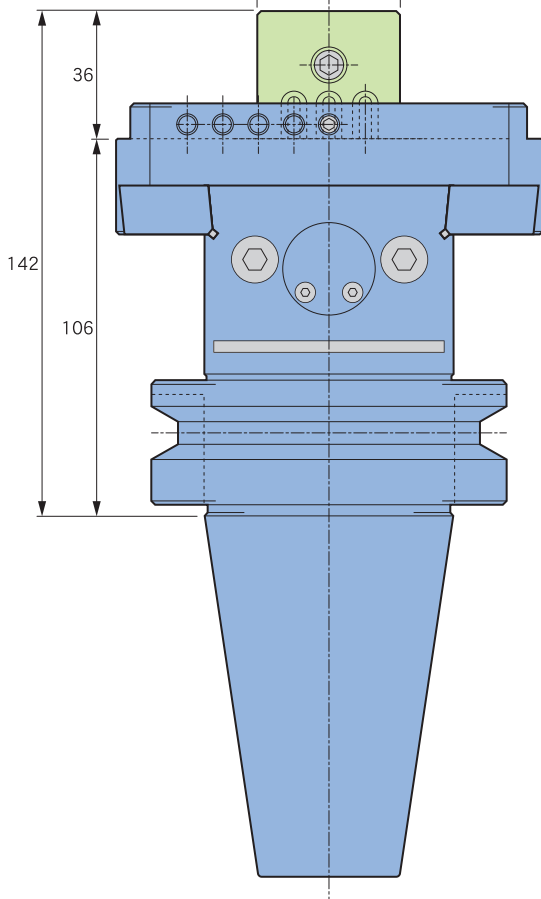
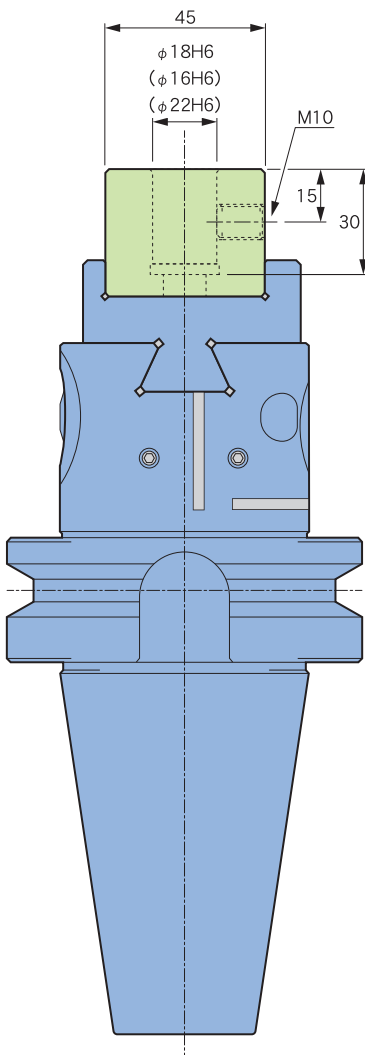

# HBA120 Round shank/2 holes

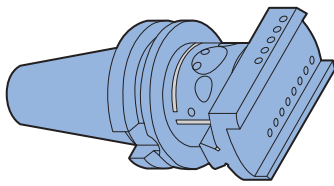

**Head**  
BT50-HBA120-106

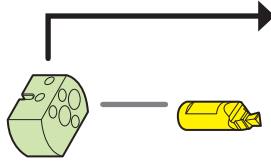

**Cartridge**  
HB-R16-2  
HB-R18-2  
HB-R22-2

**Round shank**

• Cartridge

Cartridge position	Adjustable range (offset amount)	
	Cutter position A	Cutter position B
A	0~22.5mm	20~42.5mm ※ 1
B	10~32.5mm	30~52.5mm ※ 2
C	20~42.5mm	40~62.5mm ※ 3
D	30~52.5mm	50~72.5mm ※ 4
E	40~62.5mm	60~82.5mm ※ 5

※ 1 ~ 5: For HB-R22-2, offset amount increase +4mm.

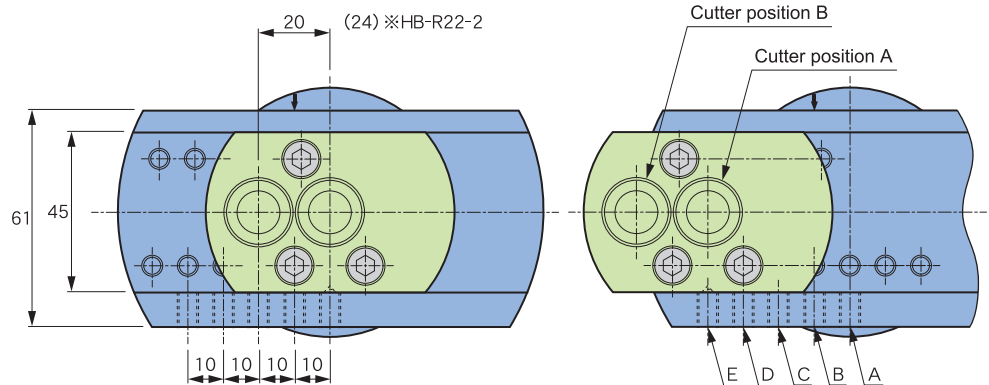

Stroke range from center: 22.5mm

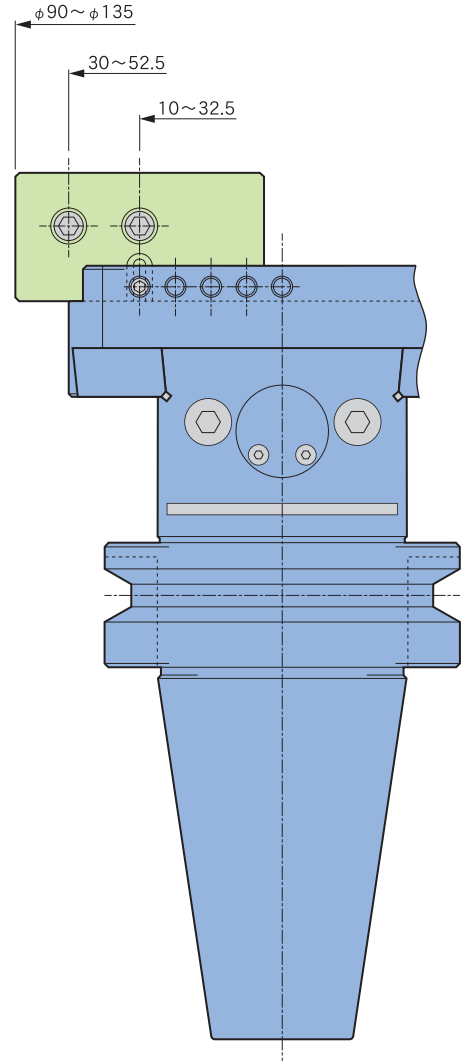
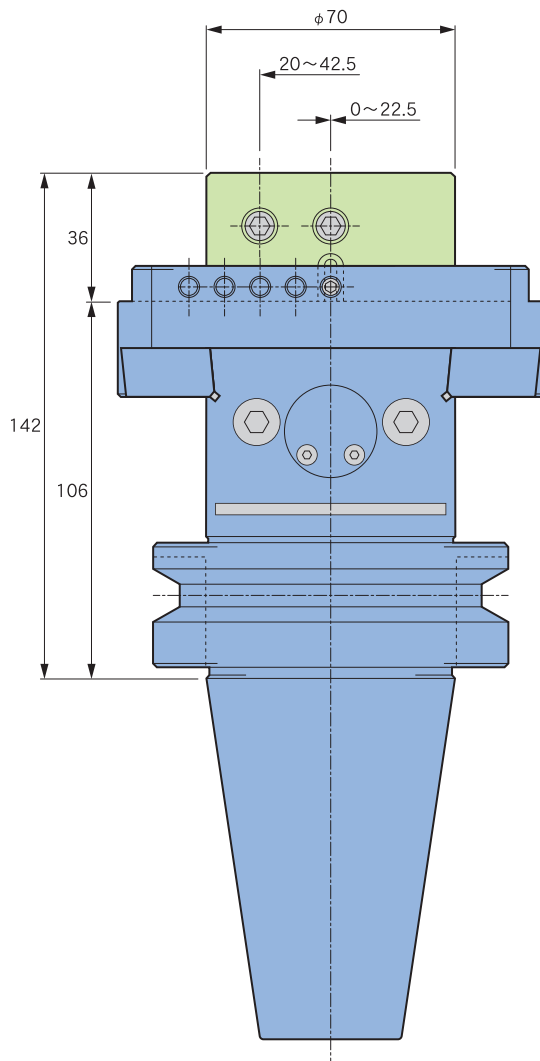
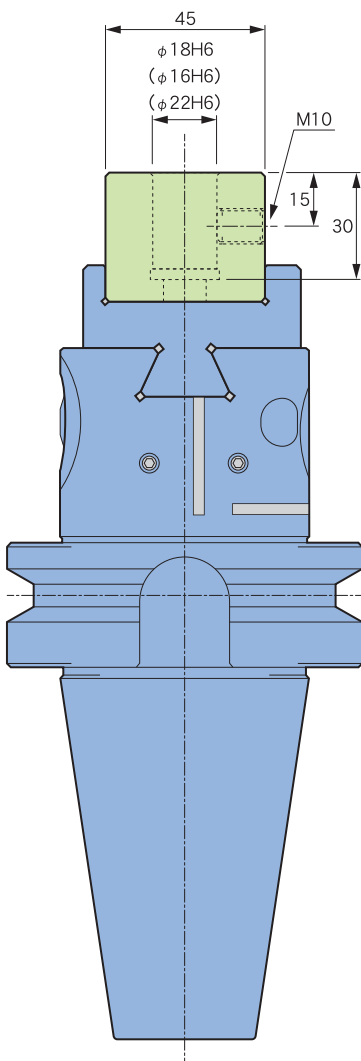

# HBA120 Blank cartridge

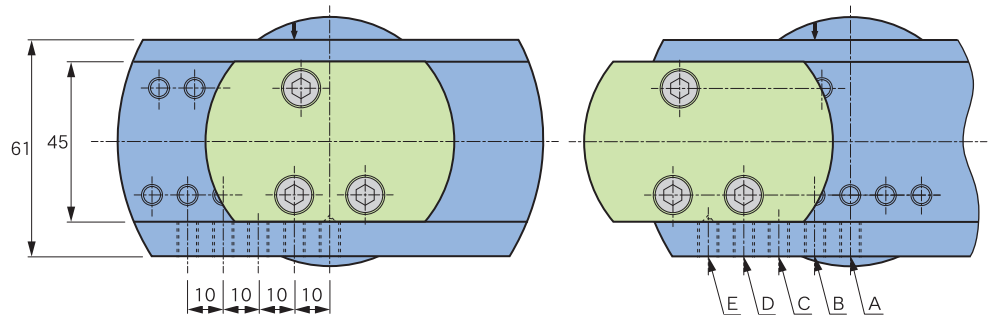
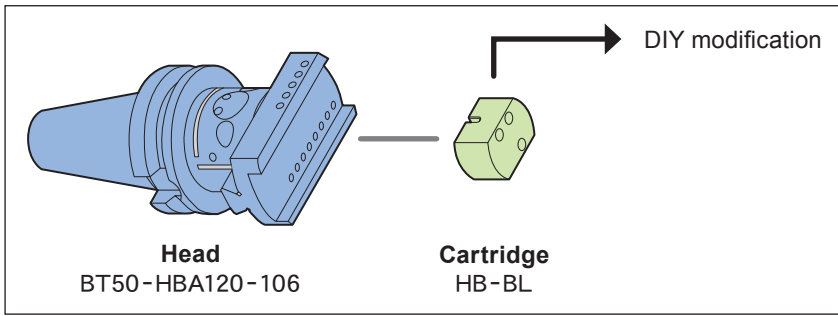

Stroke range from center: 22.5mm

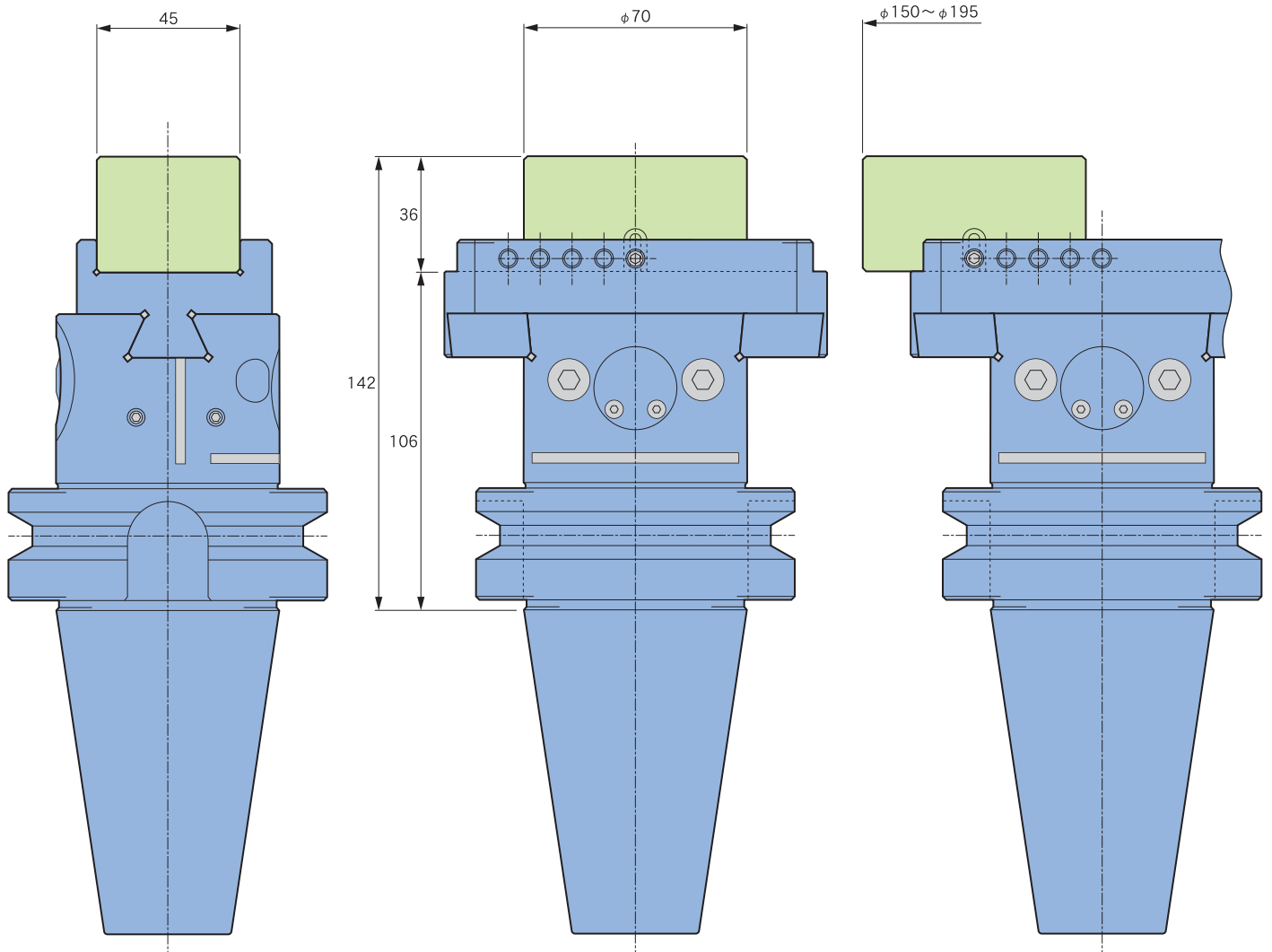
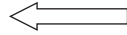

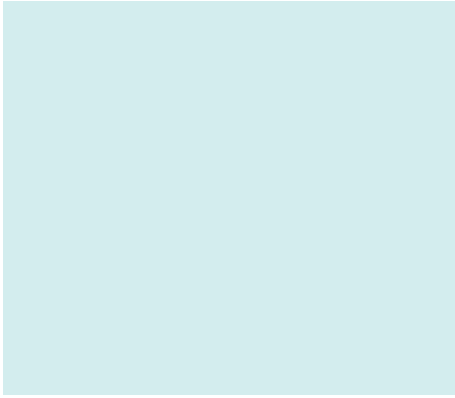
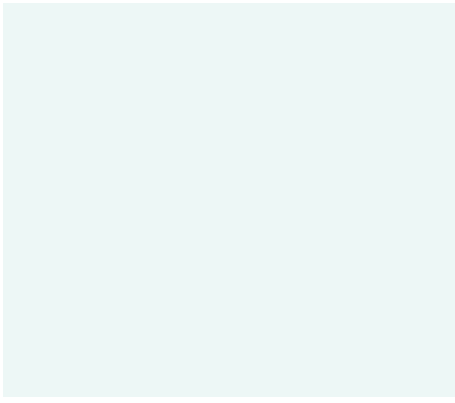

**MST**corporation

MIZOGUCHI TECHNICAL LABORATORY

1738 Kitahara Ikoma Nara 630-0142 Japan  
TEL: +81-743-78-1931  
e-mail: info@mst-corp.co.jp  
www.mst-corp.co.jp