

THE OPTIMUM TOOL HOLDERS AND WORKPIECE CLAMPER FOR 5-AXIS MACHINING

SHRINK-FIT HOLDER **SLIMLINE**
MONO **CURVE**

Achieves heavy-duty machining even though the holder and the tool have long gauge length.

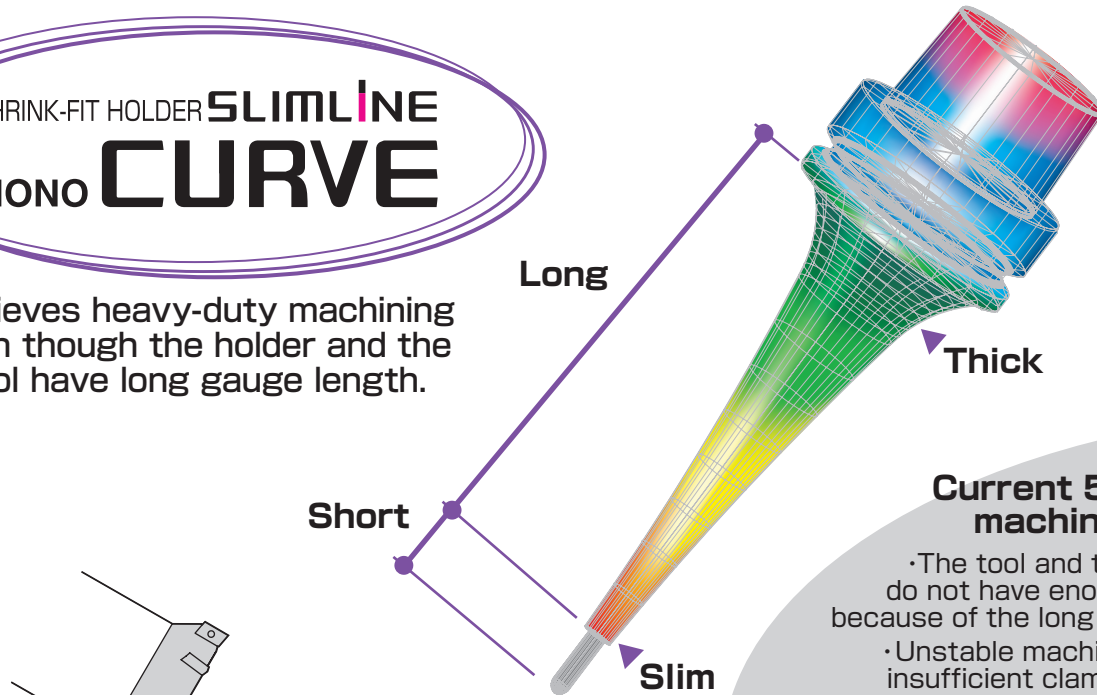

Current 5-axis machining

- The tool and the holder do not have enough rigidity because of the long tool projection.
- Unstable machining due to insufficient clamping force.
- Off-line setup not possible.

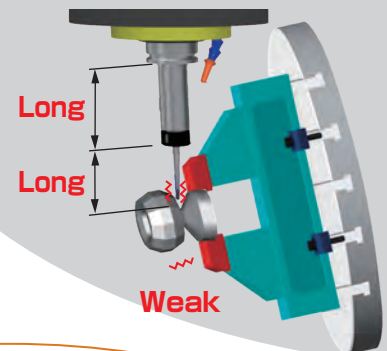

Strong • Compact

HSK 2-face contact

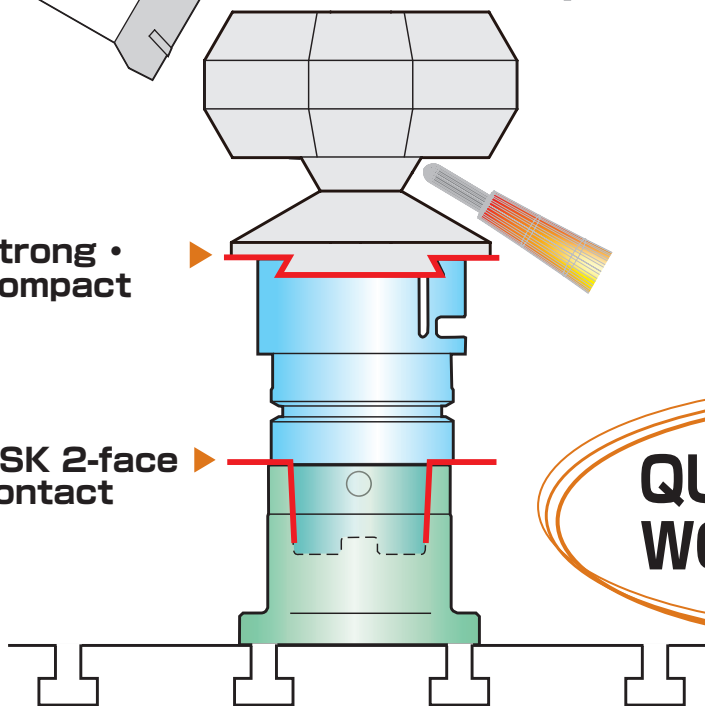

QUICK-CHANGE WORK HOLDER

Achieves superior accessibility thanks to its compact body design.



Achieves ultra-rigid machining thanks to its strong clamping force.



Changing work holders is easy. Off-line setup possible.



SHRINK-FIT HOLDER **SLIMLINE**
MONO CURVE

BT30/40/50
HSK-A63/100/125
E32/40/50
F63/80PD

60
}
345L

Unique
2-dimen-
sional
curve

Slim
type

Regular
type

1.5

3~5

φ4~20

3 μ

**THE WORK
HOLDER
AND
WORK CLAMP
DEVELOPED FOR
5-AXIS MACHINING**

**QUICK-CHANGE
WORK HOLDER
system**

**Dovetail clamping
system**

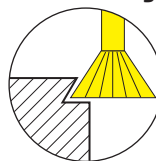

Dovetail
grooving

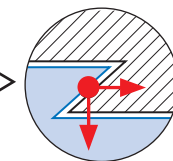

Strong clamp-
ing even though
clamping area
is small.

**Strong clamping force
and coupling rigidity**

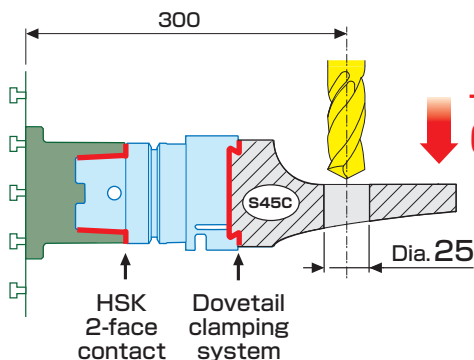

Work holder

Head

A 40
A 63
A100

ISO-HSK

MST corporation

1738 Kita-tahara, Ikoma, Nara 630-0142 Japan
TEL : +81 (0)743 78 1931
FAX : +81 (0)743 78 3854

<http://www.mst-corp.co.jp>